



Model 214 BLENDING VESSEL TRANSPORTER

NOL-TEC blending vessels are designed to provide trouble-free blending and dense phase pneumatic conveying of most materials.

STANDARD FEATURES:

- Heavy-duty design
- Smooth interior
- 60° cone
- Manway
- Erosion allowances on wear surfaces
- Butterfly valve with pneumatic actuator
- Rotatable outlets
- Total clean-out design
- Aeration jets

OPTIONAL FEATURES:

- Interior coatings
- Multiple inlets
- Stainless steel construction
- Higher pressure and temperature ratings

CODES:

- A.S.M.E. Section VIII with National Board registration

SPECIFICATIONS:

- **Design pressure:** 90 PSIG
- **Temperature range:** -20° F to +200° F

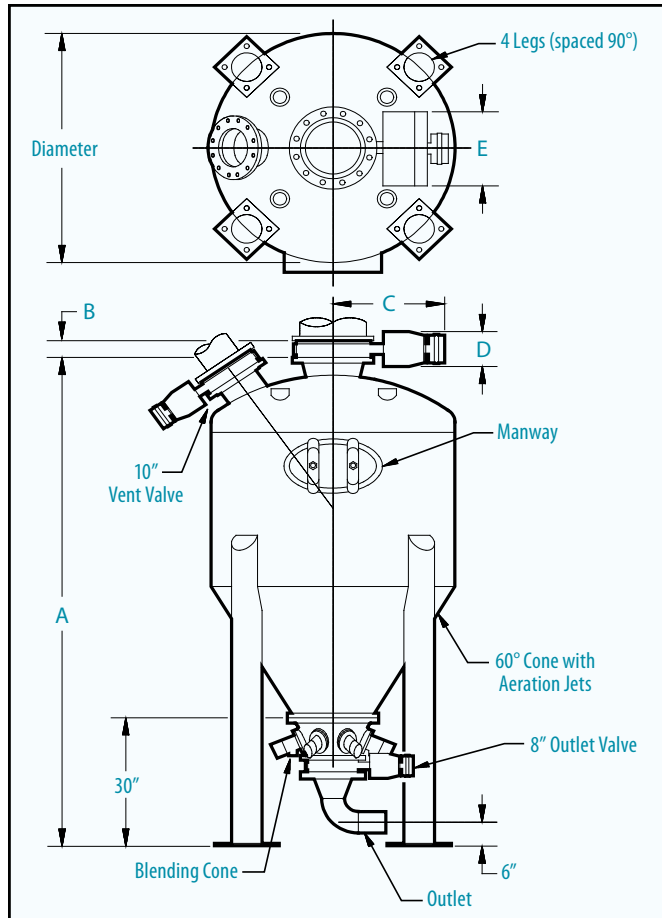

| BLENDER | | | | |
|-----------|---------------------|----------|--------|-------------|
| MODEL | CAPACITY | DIAMETER | A | SHIP WEIGHT |
| 42-60-10 | 10 ft ³ | 3' 6" | 6' 9" | 1,400 lbs |
| 42-60-20 | 20 ft ³ | 3' 6" | 7' 9" | 1,550 lbs |
| 48-60-30 | 30 ft ³ | 4' | 8' 9" | 1,800 lbs |
| 48-60-40 | 40 ft ³ | 4' | 10' 3" | 2,150 lbs |
| 48-60-50 | 50 ft ³ | 4' | 11' 3" | 2,400 lbs |
| 54-60-60 | 60 ft ³ | 4' 6" | 11' 6" | 2,800 lbs |
| 54-60-70 | 70 ft ³ | 4' 6" | 12' 6" | 3,000 lbs |
| 54-60-80 | 80 ft ³ | 4' 6" | 13' 6" | 3,250 lbs |
| 60-60-90 | 90 ft ³ | 5' | 13' 6" | 3,450 lbs |
| 60-60-100 | 100 ft ³ | 5' | 14' | 3,700 lbs |
| 72-60-150 | 150 ft ³ | 6' | 15' 3" | 4,800 lbs |
| 84-60-200 | 200 ft ³ | 7' | 15' 6" | 5,500 lbs |
| 96-60-250 | 250 ft ³ | 8' | 15' 9" | 6,700 lbs |
| 96-60-300 | 300 ft ³ | 8' | 17' 6" | 7,400 lbs |

| INLET VALVE | | | | | |
|-------------|-------|--------|----|--------|-------------|
| SIZE | B | C | D | E | SHIP WEIGHT |
| 8" | 2.5" | 20.5" | 6" | 10.88" | 60 lbs |
| 10" | 2.5" | 21.25" | 6" | 10.88" | 75 lbs |
| 12" | 3" | 23.75" | 8" | 15.75" | 150 lbs |
| 16" | 4" | 26.63" | 8" | 20" | 300 lbs |
| 18" | 4.25" | 28.25" | 8" | 20" | 335 lbs |
| 20" | 6" | 29.63" | 8" | 20" | 425 lbs |

Specifications subject to change without notice.